



**AIRCRAFT EMERGENCY LOCATOR
TRANSMITTER**

OPERATION AND INSTALLATION

**INSTRUCTIONS FOR:
MODEL 3000-11(AF)**

FOR HORIZONTAL MOUNTING IN FIXED WING AIRCRAFT
OR ANGULAR MOUNTING IN ROTARY WING AIRCRAFT.

**TSO-C91A
FCC ID JUWPNT1033E**

WARNING!

**FOR AVIATION EMERGENCY USE ONLY.
UNAUTHORIZED OPERATION PROHIBITED.**

INDEX

	PAGE:
SECTION 1 Description of Pointer ELT	2
SECTION 2 Pre-Installation Checkout	3
SECTION 3 Installation Instructions	4 thru 9
SECTION 4 Functional Testing	10 and 11
SECTION 5 Operating Instructions	12 and 13
SECTION 6 Battery Information	14
SECTION 7 Performance Requirements and Specifications	15

SECTION 1 DESCRIPTION

- 1-1 POINTER ELT is a self-contained emergency locator transmitter capable of manual or automatic operation.
- 1-2 POINTER ELT is designed to withstand forced landing and crash environmental conditions and survive in an operable condition. The highest quality materials and components have been selected for manufacturing to insure rugged, reliable emergency equipment.
- 1-3 Automatic activation is accomplished by a deceleration sensing inertia switch. The inertia switch is designed to activate when the unit senses longitudinal inertia forces as required in TSO-C91A.

NOTE: When properly installed, parallel to the line of flight, POINTER ELT will not activate due to turbulence, normal operations, or aerobatics.

- 1-4 POINTER ELT (see Figures 1 and 2) consists of:
- A. A high-impact, fire retardant, waterproof case with carrying handle.
 - B. A solid-state transmitter operating at the assigned emergency frequencies of 121.5 MHz and 243.0 MHz. Automatic transmission is modulated by a distinctive downswept tone.
 - C. A battery pack consisting of five alkaline "C" cells in an impact resistant fabricated foam housing (P/N 2020).
 - D. RF coaxial connector outlet for antenna.
 - E. A remote "ON-AUTO-RESET" control jack.
 - F. A master "ON-OFF-AUTO" switch.
 - G. A preformed anodized quick-detach mounting bracket (P/N 2017-10).
 - H. A Master Switch Clip (P/N 2021).
 - I. An operation and installation manual.
 - J. A warranty registration card.
 - K. "ELT LOCATED HERE" Decal.

SECTION 2 PRE-INSTALLATION

2-1 POINTER ELT is designed to be installed in the aft section or cabin of the aircraft. Submission of FAA Field Approval Form 337 is required. The installation and testing should be made by in accordance with EA-AC 43.13-2A by qualified personnel. Appropriate weight and balance computations shall be completed and entered in the Aircraft Logbook for each installation.

2-2 PRE-INSTALLATION PREPARATION PROCEDURE

- a. Remove POINTER ELT from carton and remove foam guard from master switch. Verify the master switch is in the "OFF/RESET" position (See Fig. 1).

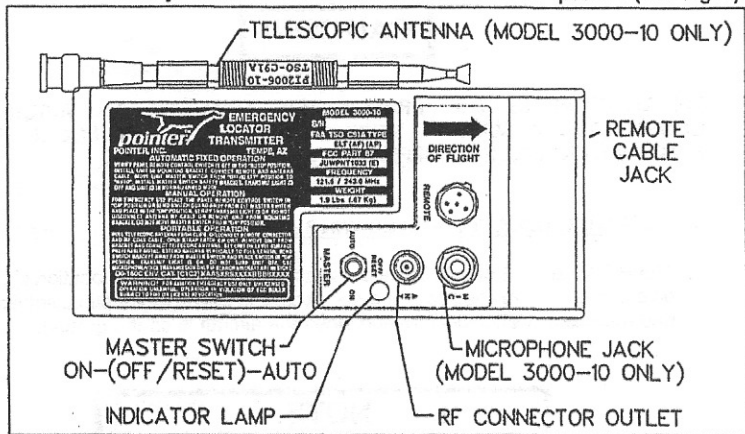

FIGURE 1. POINTER 3000-10,11 OPERATING DETAILS

- b. Install 50 ohm load on antenna RF output.
- c. Place master switch in the "AUTO" position.
- d. Shake the unit firmly parallel to the "DIRECTION OF FLIGHT" arrow on the unit face. A down sweeping tone will be heard on the monitoring radio at 121.5 MHz.
- e. Place the master switch in the "ON" position. Unit should again operate.
- f. Place the master switch in the "OFF" position. POINTER ELT IS NOW READY FOR INSTALLATION.

NOTICE

IF FOR ANY REASON THE POINTER ELT DOES NOT TRANSMIT DURING ANY OF THE ABOVE TESTS, REPEAT THE PROCEDURES. IF UNIT STILL FAILS TO OPERATE, RE-PACKAGE THE ENTIRE UNIT AS SHIPPED, COMPLETE THE REGISTRATION CARD, PLACE A NOTE OF EXPLANATION AND THE REGISTRATION CARD INSIDE THE BOX AND RETURN UNIT TO DEALER OR FACTORY FOR REPLACEMENT.

**SECTION 3
INSTALLATION INSTRUCTIONS**

3.0 GENERAL

The following instructions are a general guide for the installation of the POINTER Aircraft Emergency Locator Transmitter. Installation shall be made in accordance with the requirements of FAA document AC 43-13-2, ACCEPTABLE METHODS, TECHNIQUES, & PRACTICES - AIRCRAFT ALTERATIONS. Each installation must satisfy airworthiness requirements pertinent to type.

CAUTION!

INSTALLATION IN THE PRESSURIZED AREA OF AN AIRCRAFT CONSTITUTES A MAJOR MODIFICATION. CONSULT LOCAL FAA REGIONAL ENGINEERING OFFICE BEFORE PROCEEDING.

3.1 MOUNTING LOCATION - FIXED-WING AIRCRAFT

- a. The POINTER ELT should be mounted as far aft as possible. Location should be chosen to afford easy and repeated access to the ELT for testing, servicing, and manual activation/deactivation when the aircraft is on the ground.

NOTE:

**FOR AUTOMATIC PORTABLE (AP)
INSTALLATION: Mounting location
should afford easy removal of the ELT
from the aircraft for detached operation.**

- b. Select an area in the cabin such as between the seats, in the luggage area, cabin floor, radio equipment rack, or any flat surface parallel to the longitudinal axis of the aircraft. Assure that the mounting area is solid.
- c. It is important that the unit be mounted PARALLEL TO or SLIGHTLY ABOVE the line of flight in fixed-wing aircraft. The POINTER ELT must be solidly mounted. DO NOT install in an area subject to flexing or drumming vibrations. See Section 3.3 and 3.4 for installation details.

3.2 MOUNTING LOCATION - ROTARY-WING AIRCRAFT (HELICOPTER)

- a. The POINTER ELT must be located on the primary structure. This location must be accessible for manual activation/deactivation, testing, and servicing when the helicopter is on the ground. See Section 3.4 for installation details.

NOTE:

FOR AUTOMATIC PORTABLE (AP) INSTALLATIONS: Mounting location should afford easy removal of the ELT from the helicopter for detached operation.

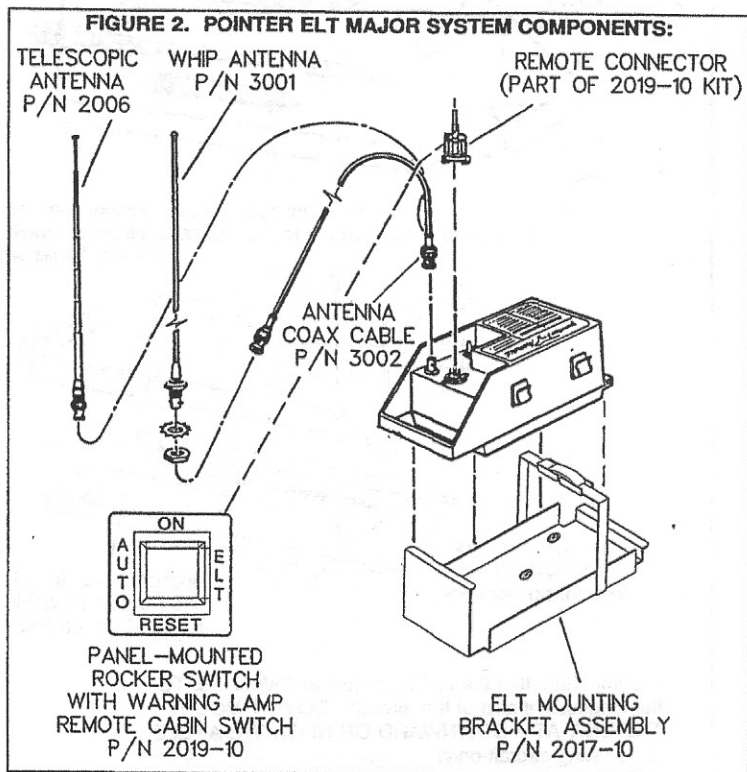

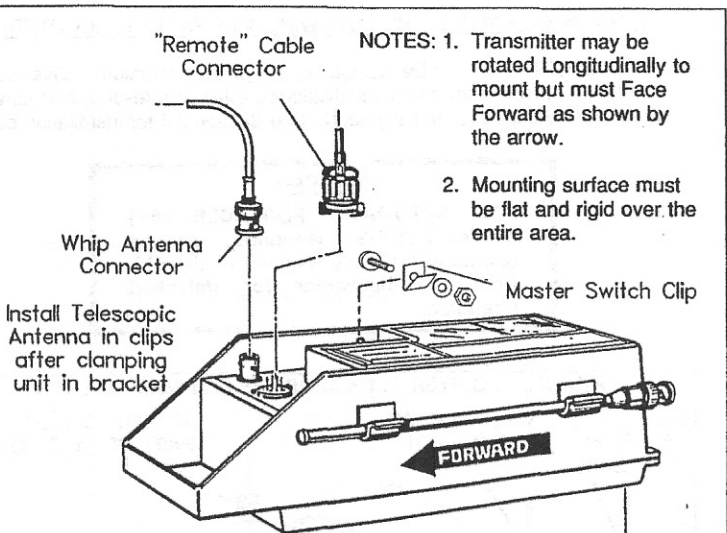

6 Panhead screw, washer and nut.
All mounting hardware to be suitable aircraft quality.
(4 ea. Minimum)

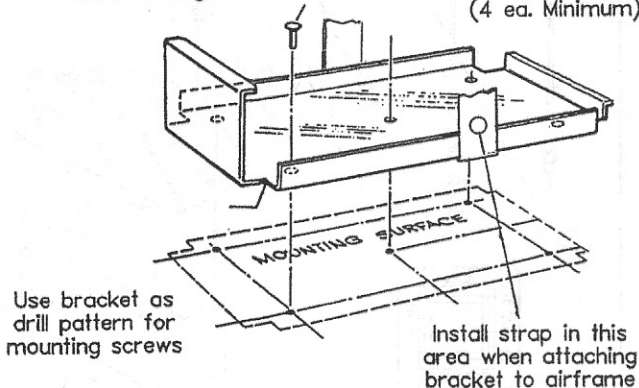

It is important that the unit be mounted PARALLEL TO the longitudinal axis of the aircraft. DO NOT MOUNT THE UNIT AT A DOWNWARD OR NEGATIVE ANGLE. (Fixed-wing aircraft only)

FIGURE 3. MOUNTING POINTER ELT IN FIXED-WING AIRCRAFT

3.3 ELT INSTALLATION DETAILS - FIXED-WING AIRCRAFT

NOTE:

Prior to installing the ELT transmitter, check that the battery replacement date is marked in the space on the label at the end of the unit.

- 3.3-1 Attach mounting bracket to the aircraft structure so that, when the unit is installed, the "DIRECTION OF FLIGHT" arrow on the ELT control face points forward in the direction of flight. Drill five holes and attach the mounting bracket with #6 pan head screws. All attaching hardware must be of material and type suitable for Aircraft application. Heads must be flush with bracket surface.
- 3.3-2 Figure 3 shows a typical fixed-wing aircraft installation. Insert transmitter into the mounting bracket and position bracket strap forward of rear telescopic antenna clip and over the unit case. Open latch, attach to clip and lock into place.
- 3.3-3 Install telescopic antenna in clips as shown. (Model 3000-10 only)
- 3.3-4 Set the Master Switch to the "AUTO" position and install Master Switch clip.
- 3.3-5 Record the installation in Aircraft Logbooks.
- 3.3-6 A remote whip antenna and coaxial cable are provided with model 3000-10 for external mounting. See Section 3.5 for antenna mounting details.
- 3.3-7 EXTERNAL MARKING. An "ELT LOCATED HERE" decal is supplied to indicate transmitter location.

3.4 INSTALLATION DETAILS - ROTARY-WING (HELICOPTER)

- 3.4-1 All mounting instructions are identical to Fixed-Wing with the exception of the mounting angle as shown in Figure 4.

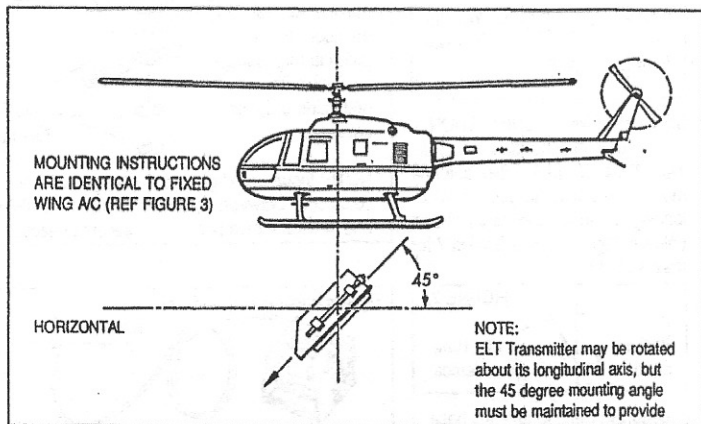

FIGURE 4. MOUNTING POINTER ELT IN ROTARY-WING AIRCRAFT

3.5 WHIP ANTENNA LOCATION AND MOUNTING

3.5-1 The POINTER 3000-10 Whip Antenna and coaxial cable are provided to permit external antenna radiation. Use ONLY the cable furnished with the unit. Whip antenna should be mounted as far aft as possible on the surface of the aircraft (or helicopter) as this area is normally less susceptible to impact damage.

Pay particular attention to the following:

- Mount Whip Vertically on the upper surface of aircraft (or helicopter).
- Locate so as to minimize RF coupling from adjacent communications antennae. Maintain maximum practical distance from all other antennae.
- Must not foul other antennae when whipped in flight.
- Mount Whip antenna as close as possible to transmitter. Neatly coil and tie any excess in the 5 foot coax cable. Coaxial cable must not be cut or altered.

3.5-2 WHIP ANTENNA INSTALLATION

Figures 5 and 6 illustrate details of Metal and Fabric-skin aircraft antenna installations.

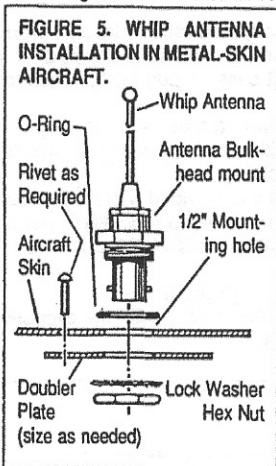
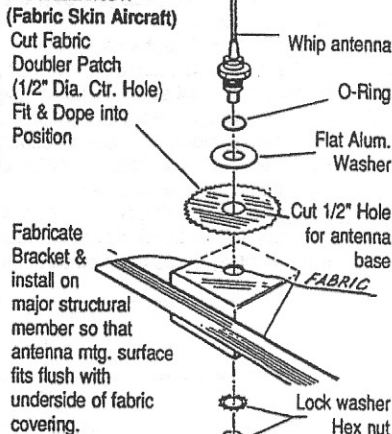

FIGURE 6. WHIP ANTENNA INSTALLATION (Fabric Skin Aircraft)



NOTE: Insure good ground connection between bracket and structural member. Apply Loctite or Glyptal Red 90-2 to secure threads.

3.5-3 ANTENNA MODIFICATION

For high performance aircraft. The POINTER ELT Whip antenna may be modified to reduce wind-loading at higher speeds as shown below in Figure 7. (See Section 7 for max. speed.)

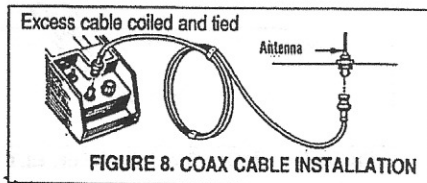
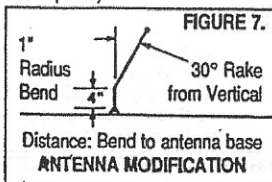

3.6 REMOTE SWITCH OPTION

The Remote Switch is required for all installations where the transmitter is inaccessible or not visible to the pilot in flight. This enables the pilot to remotely control the transmitter in flight. This is also useful for ground testing without gaining access to the transmitter.

3.6-1 Items included in the Remote Switch kit are as listed below:

DESCRIPTION	QTY.	DESCRIPTION	QTY.
Rocker switch, DPDT	1	Remote Connector (Locking)	1
Switch Terminal Cover	1	Face Plate, ON/AUTO/RESET	1
		FCC Warning Label	1

3.6-2 The Remote Switch Wiring diagram is shown in Figure 9.

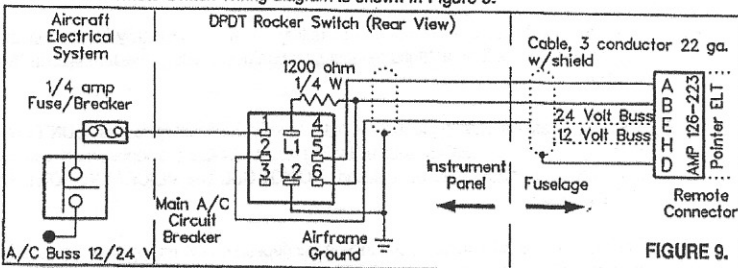

FIGURE 9.

3.6-3 Select a location on the instrument panel for the Remote Switch/Face plate assembly. A 3/4" square hole is required for switch installation.

3.6-4 Figure 10 shows pin/terminal details for the connector and remote switch. Connect the wires as shown in Figure 9 using ONLY the connector and switch supplied in the kit.

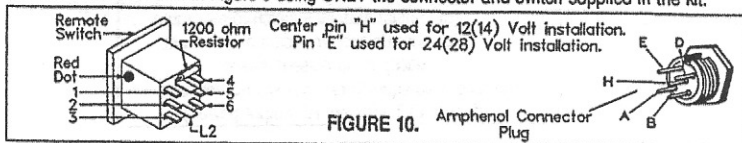

FIGURE 10.

- 3.6-5 At panel end of cable, remove outer cable covering, form shielding into pigtail. Connect pigtail to aircraft ground.
- 3.6-6 At transmitter end of cable, remove cable covering and form shielding into pigtail. Connect with pin D of the remote connector.
- 3.6-7 A fuse (1/4 amp max) must be installed in the aircraft power circuit to the Remote Switch.
- 3.6-8 12/24V aircraft. The remote switch "#2" terminal must be connected to the Remote Connector "H" pin in 12/14 Volt systems, and to the "E" pin in 24/28 Volt systems.
- 3.6-9 Before mating the remote connector to the transmitter, apply sufficient silicone grease compound (DC-4) to mating surfaces that the surplus is forced out during connection for a moisture seal.
- 3.6-10 Press the Remote Switch into the instrument panel over the face plate.
- 3.6-11 Affix the warning label to the instrument panel above, below, or adjacent to the Remote Switch/Face Plate to comply with FCC Requirements. This completes Remote Switch Installation.

SECTION 4
FUNCTIONAL TESTING

4.0 GENERAL

The POINTER ELT System must undergo a functional test for the following reasons:

- (a) After initial installation
- (b) After system maintenance, such as battery pack replacement.
- (c) Thereafter at owner's or operator's discretion. Annual or more frequent inspection intervals are recommended.

4.1 TEST PREPARATION

- 4.1-1 Visually inspect unit, connections and mounting bracket occasionally for cleanliness and secureness. Check fixed antenna mounting for tightness. Verify master switch in "AUTO" position.
- 4.1-2 Test unit occasionally using procedures outlined in FAA advisory circulars. **DON'T** overtest. If more than one cumulative hour of testing occurs before the replacement date of the battery pack, the pack should be replaced. **DO NOT USE THE VOICE FUNCTION DURING TEST PERIODS.**
- 4.1-3 The clarity of the voice modulation function will depend on the microphone type used. The transmitter is designed to use a carbon type microphone. Modulation level is intentionally low to prevent total carrier interruption during voice transmissions. **Remember, to conserve batteries, do not use voice function until you are positive search aircraft are in the area.**

NOTE: Where aircraft comm. receiver is used:

- (a) Tune to 121.5 MHz
- (b) Adjust manual squelch to maximum.
- (c) turn up receiver volume until slight background noise is heard

(An automatic squelch receiver will not reveal a defective ELT with low RF output power.)

4.2 POINTER ELT FUNCTIONAL DETAILS

- 4.2-1 **AUTOMATIC PORTABLE (AP).** (Unit installed without the remote switch).
The unit Master Switch functions are as follows:

AUTO: Used to arm the POINTER ELT for automatic activation by the "G" switch only.

ON: Used to activate the transmitter for test or emergency situations. The ON switch bypasses the automatic activation switch.

OFF/RESET: Used to de-activate the transmitter during handling and to reset the automatic activation function.

- 4.2-2 **"G" Switch:** Used to activate the POINTER ELT in an emergency situation. The "G" switch can be operated by impact only.

4.2-3 **AUTOMATIC FIXED (AF)** (unit installed WITH the remote switch)
 The Remote Switch functions as follows: (With Master Switch in "AUTO" position)

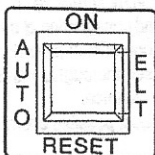

ON: Used to remotely activate the transmitter for a test or emergency situation. An example of such an emergency situation would be a forced landing with an impact insufficient to activate the "G" switch.

AUTO: Used to arm the POINTER ELT for automatic activation by the "G" switch.

RESET: Used to deactivate and rearm the transmitter after automatic activation by the "G" switch.

4.3 **FUNCTIONAL TEST OF AIRCRAFT-INSTALLED POINTER ELT**

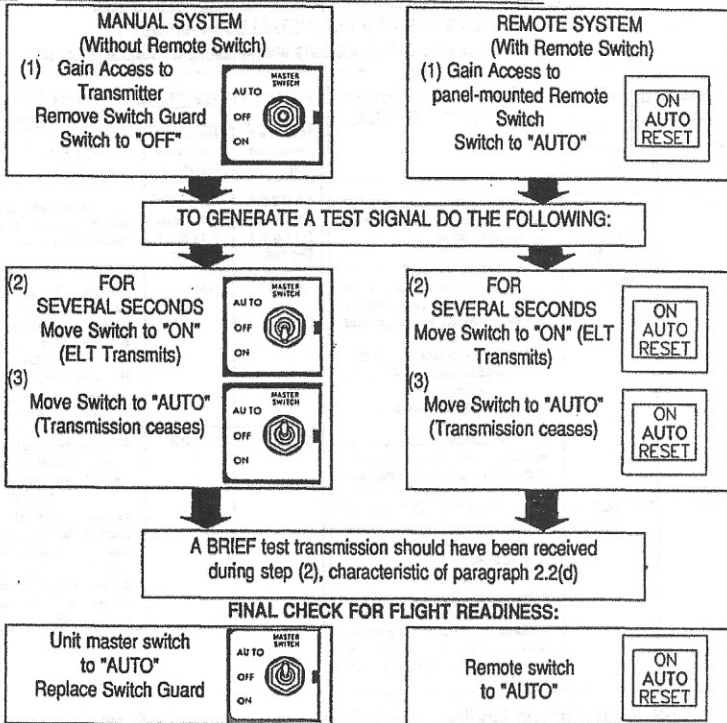

4.4 **MAINTENANCE**

4.4-1 If the ELT fails to operate properly during the functional test, remove only the main unit and return to manufacturer for inspection and repair.

SECTION 5
OPERATING INSTRUCTIONS

- 5.0 GENERAL. Your POINTER ELT has been engineered to provide the most reliable operation possible. Every contingency has been considered in the design and construction of the ELT system. The following section will acquaint you with the simple operational procedures of the POINTER ELT. It is recommended that you familiarize yourself thoroughly with these procedures and have them firmly in mind to add to your flying confidence.
- 5.1 It is recommended that the following steps be taken to insure the best possible operation in an emergency:
- Become thoroughly familiar with the POINTER ELT instructions.
 - Keep them on hand in the aircraft at all times.
 - Visually inspect the unit at regular intervals for cleanliness and secureness. Check External antenna mounting and cable connections for tightness.
- 5.1-1 OPERATING MODES OF POINTER ELT INSTALLED IN AIRCRAFT.
The following table gives the switch positions and functions for various situations.

MANUAL SYSTEM (Pointer ELT System Without Remote Switch)			REMOTE SYSTEM (Pointer ELT System With Remote Switch)		
MODE	Master Switch on Unit	FUNCTION	Master Switch on unit	Remote Switch on Panel	FUNCTION
AUTO	"AUTO" (Normal Flight Setting)	ELT automatically activated if "G" switch senses predetermined deceleration level.	"AUTO" (Normal Flight Setting)	"AUTO" (Normal Flight Setting)	ELT automatically activated if "G" switch senses predetermined deceleration level.
MANUAL	"ON"	Overrides "G" switch, and turns ELT on so it can be tested for proper operation on the ground OR: (ONLY IF TRANSMITTER IS ACCESSIBLE WHILE AIRBORNE) Airborne Testing OR: If emergency situation is imminent and pilot wishes to activate ELT prior to emergency	"AUTO"	"ON"	Overrides "G" switch and turns ELT on so it can be tested for proper operation on the ground or while airborne. OR: If emergency situation is imminent and pilot wishes to activate ELT prior to emergency.
OFF	"OFF/RESET"	Turns POINTER ELT off in preparation for removal from aircraft or to discontinue signal after rescue. NOTE: If inadvertent activation occurs in system the transmitter can be restored to "ARMED" status by moving master switch to "OFF/RESET" position and then to "AUTO".	"AUTO"	"RESET"	Returns Pointer to "AUTO" armed mode if inadvertent activation of the "G" switch should occur. NOTE: Aircraft electrical power is required for remote Reset. In case of inadvertent activation with Master power off, turn aircraft Master electrical power on, reset ELT, then return Master switch to off.

- 5.1-2 After a forced landing, if aircraft receiver is operable, listen on 121.5 MHz for POINTER ELT transmissions. Ensure that external antenna is clear of obstructions.
- 5.1-3 The range of POINTER ELT varies according to weather and topography. In general, the swept tone signal can be heard up to 30 miles by a search aircraft at 10,000 Ft. Stay close to the downed aircraft to permit easier spotting by airborne searchers.

5.2 OPERATING POINTER ELT IN THE PORTABLE MODE.

5.2-1 After forced landing or aircraft accident it may be desirable to use POINTER ELT in the portable mode. Various reasons may necessitate this, such as:

- | | |
|---|---|
| (a) Broken or disabled whip antenna | (d) Temperature extremes in aircraft |
| (b) Severed whip antenna cable | (e) Poor transmitting location |
| (c) Danger of fire or explosion in aircraft | (f) Water ditching forces abandonment of aircraft |

5.2-2 REMOVAL OF TRANSMITTER FROM AIRCRAFT.

NOTE: ACCOMPLISH AS QUICKLY AS POSSIBLE TO RESUME OR START EMERGENCY SIGNAL

- (a) Bend Switch Guard away from unit Master Switch and place switch in "OFF" position.
- (b) Disconnect Remote Antenna cable
- (c) Disconnect Remote Switch cable (if installed)
- (d) Remove Telescopic Antenna from stowage clips. Unlatch unit hold down strap and remove unit from bracket.
- (e) Insert Telescopic Antenna into the "ANT" receptacle. Extend antenna fully.
- (f) Turn unit master switch to "ON" position. DO NOT USE "AUTO" POSITION!

5.2-3 Consider such factors as Terrain, Temperature and precipitation when choosing a location for the transmitter to radiate from.

BEST TRANSMISSION MAY BE OBTAINED BY:

- (a) Keeping antenna vertical
- (b) Setting transmitter upright on a metallic surface, such as an aircraft wing or stabilizer.
- (c) If terrain prohibits good transmission (such as a deep valley or canyon), place the transmitter on high ground or hold in hand on high place.

YOUR POINTER ELT is supplied with a battery pack designed to withstand the environmental extremes. However, the life of the battery pack can be extended by the following steps:

- (d) In freezing weather, place transmitter inside jacket or coat to keep the battery warm. Let antenna extend outside jacket.
- (e) Keep all moisture and ice away from the antenna connection and the remote connector pins.

CAUTION: DO NOT TURN POINTER ELT OFF - EVEN AT NIGHT as the satellite search & rescue system operation is continuous. Even when you have been sighted or think you have, the spotting aircraft may not be able to relay an accurate or timely "fix" on your position without a continued signal.

5.3-2 ONLY WHEN THE RESCUE TEAM APPEARS discontinue signal by shutting unit "OFF".

SECTION 6 BATTERY INFORMATION AND REPLACEMENT

6 GENERAL

- 6.1 Power is derived from a pre-formed foam battery pack consisting of 5 1.5V Alkaline "C" size batteries in series. This assembly has been moisture-sealed and fitted with a battery lead connector.
- 6.2 WHEN TO REPLACE BATTERY PACK:
- 6.2-1 In accordance with FAA regulations, batteries must be replaced after 2 years shelf or service life or for any of the following reasons:
- After the transmitter has been used in an emergency situation (including any inadvertent activation of unknown duration).
 - After the transmitter has been operated for more than one cumulative hour (e.g. time accumulated in several tests and an inadvertent activation of known duration).
 - On or before battery replacement date. (Battery replacement date is marked on the battery pack and the label at end of transmitter.)

Check with your local dealer or distributor for approved replacement battery packs.

WARNING: DO NOT ATTEMPT TO RECHARGE BATTERY PACK!

- 6.3 REMOVING THE TRANSMITTER FROM THE AIRCRAFT (See Figure 11)
- 6.3-1 Transmitter must be removed from aircraft for battery replacement by the following steps:

- Remove Switch Guard and place the Master Switch in the "OFF" position.
- Disconnect the antenna cable, and, where applicable, the remote connector.
- Remove Telescopic Antenna, open latch on hold-down strap, and remove Transmitter from mounting bracket.

- 6.4 REMOVE BATTERY PACK AS FOLLOWS:

- Remove 6 screws from back cover. (Retain Teflon washers)
- Remove cover (save gasket), and disconnect the battery/transmitter connectors.
- Remove and replace battery pack, reversing the above procedure.
- Exercise care not to overtighten the 6 base plate screws upon reassembly.

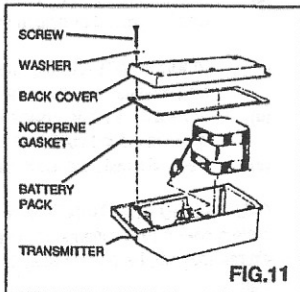

- 6.5 Apply new battery replacement date label, supplied with replacement pack, on transmitter end prior to re-installing transmitter in aircraft.
- 6.6 After re-installing transmitter in aircraft, test in accordance with Section 2.2 and Section 4.3 - Functional testing, Page 11.

SECTION 7

POINTER ELT TEST SUMMARY
Required FAA TSO-C91A Tests

MODEL (TYPE)	OPERATING LIFE		SHOCK	VIBRATION
	Low-Temp Requirement: -55°C soak, 30 min. Operate -20°C for 50 hours.	Hi-Temp Requirement: +45°C soak, 30 min. Operate 2 hrs. +35°C, 22 hrs. +30°C. Repeat 24 hour cycle.		
AUTOMATIC FIXED (AF) REMOTE ANTENNA	Modulation Rate: 2.4 Hz Modulation Range: 1428 Hz - 416 Hz Carrier Frequency: 121.49790 MHz Duty Cycle: 50% Modulation Factor: 100% P.E.R.P.: 121.5 MHz; 75 mW 243.0 MHz; 75 mW	Modulation Rate: 3.2 Hz Modulation Range: 1583 Hz - 478 Hz Carrier Frequency: 121.49613 MHz Duty Cycle: 50% Modulation Factor: 100% P.E.R.P.: 121.5 MHz; 135 mW 243.0 MHz; 135 mW	100 G Requirement: Half-sine pulse 20 mSec. six axis	Swept Frequency 10G peak 5 Hz to 200 Hz, three axis Modulation Rate: 3.2 Hz Modulation Range: 1583 Hz - 500 Hz Carrier Frequency: 121.49664 MHz Duty Cycle: 50% Modulation Factor: 100% P.E.R.P.: 121.5 MHz; 160 mW 243.0 MHz; 140 mW
AUTOMATIC PORTABLE (AP) TELESCOPIC ANTENNA	Results same as above except: P.E.R.P.: 121.5 MHz; 60 mW 243.0 MHz; * Not Rated	Results same as above except: P.E.R.P.: 121.5 MHz; 110 mW 243.0 MHz; * Not Rated	Results same as above except: P.E.R.P.: 121.5 MHz; 140 mW 243.0 MHz; * Not Rated	Results same as above except: P.E.R.P.: 121.5 MHz; 140 mW 243.0 MHz; * Not Rated

TRANSMITTER PARAMETER LIMITS
MODULATION CHARACTERISTICS:

Range: 1600 Hz - 300 Hz
 Excursion: 700 Hz minimum
 Rate: 2 Hz - 4 Hz

RF CHARACTERISTICS:

Frequency: 121.493925 MHz - 121.506075 MHz 243.0 MHz. Harmonically related to fundamental
 Peak Effective Radiated Power (PERP): 50 mW minimum after 50 hours at -20°C (-4°F).

ENVIRONMENTAL TESTS
MECHANICAL

Impact: 1.0 X 0.5 inch probe with 55 lb. mass
 dropped six inches to unit surface.
 Crush: Unit compressed 1000 lb. vertically and laterally.

TEMPERATURE

Temperature Variation: Unit cycled -20°C - +55°C; two cycles, 6 hr. Cycle Par 2.3.2.
 Altitude: Pressure altitudes raised to 35 Kft. and held for two hours, vented to SL.

MOISTURE

Humidity: Unit maintained at 95% humidity, 38°C to 50°C variation for 48 hrs.
 Spray: Two hours, ambient temperature
 Immersion: Unit submerged in 5% salt water for 24 hrs. at 40°C

ELECTRICAL

RF Reradiation: Par. 2.2.7
 RF Susceptibility: Par. 2.2.8
 Audio Induced and Conducted Susceptibility: Par. 2.3.14
 Voltage Spike Test: Par. 2.3.13

The transmitters subjected to the above environmental tests remained within the required operating parameters throughout the environmental test program.

System Weights:

TRANSMITTER (including primary battery, telescopic antenna & mtg. bracket) 1.9 lb. (.86 Kg)
REMOTE ANTENNA (including coaxial cable and connector) 0.25 lb. (.11 Kg)
LIMITATIONS: Whip Antenna 175 Kts MAS (May be swept back per Fig. 7 for 225 Kts)
 * Telescopic Antenna optimized for 121.5 MHz portable use.

Dimensions (Transmitter)
 7.56" x 3.12" x 2.34" (19.4 cm x 9 cm x 7 cm)

WARRANTY

POINTER, INC. warrants each new Pointer Emergency Locator Transmitter to be free of defects in material and workmanship, to the original purchaser, indefinitely provided the unit is equipped with a Pointer, Inc. manufactured battery pack. The Company will repair or replace, free of charge, at its factory, any part or parts found to be defective under normal use and service - *PROVIDED* that the enclosed warranty card is properly completed and mailed within 15 days after installation and is on file with *POINTER*. This warranty does not cover shipping cost or removal and reinstallation of unit in the aircraft.

This warranty does not cover defects resulting from alterations, improper use, or installation, tampering or failure of the purchaser to follow normal operating procedures outlined in the user's instructions, nor for example, does it cover damage resulting from acts of God, such as floods, tornadoes, or lightning.

This warranty is made only to original purchasers in the United States and does not cover the responsibility for the shipping expenses in returning the transmitter or accessory to *POINTER* or return to the purchaser.

THE WARRANTY PROVISIONS SET FORTH ABOVE ARE IN LIEU OF ANY AND ALL OTHER WARRANTIES, WHETHER EXPRESSED OR IMPLIED, INCLUDING THE WARRANTIES OF MERCHANTABILITY OR FITNESS FOR A PARTICULAR PURPOSE, AND ANY OTHER OBLIGATIONS OR LIABILITY WHATSOEVER ON THE PART OF *POINTER, INC.* OR ANY OF ITS FRANCHISED DEALERS.

NOTICE

The following instructions are a general guide for the installation of *Pointer Automatic Emergency Locator Transmitters*. Installation should be made in accordance with FAA installation requirements by an approved installation facility.



MFG. BY POINTER, INC.

1027 N. STADEM DRIVE TEMPE, ARIZONA 85281