



**AIRCRAFT EMERGENCY LOCATOR  
TRANSMITTER**

**OPERATION AND INSTALLATION**

**INSTRUCTIONS FOR:**

**MODEL 3000 (AP)(AF)**

FOR HORIZONTAL MOUNTING IN FIXED WING AIRCRAFT  
OR ANGULAR MOUNTING IN ROTARY WING AIRCRAFT.

**WARNING!**

**FOR AVIATION EMERGENCY USE ONLY.  
UNAUTHORIZED OPERATION PROHIBITED.**

## INDEX

	PAGE:
SECTION 1 Description of Pointer Portable ELT	2
SECTION 2 Pre-Installation Checkout	3
SECTION 3 Installation Instructions	4 THRU 9
SECTION 4 Functional Testing	10 and 11
SECTION 5 Operating Instructions	12 and 13
SECTION 6 Battery Information	14
SECTION 7 Performance Requirements and Specifications	15

### SECTION 1 DESCRIPTION

- 1 POINTER PORTABLE is a self contained emergency locator transmitter capable of manual or automatic operation.
- 2 POINTER PORTABLE is designed to withstand forced landing and crash environmental conditions and survive in an operable condition. The highest quality materials and components have been selected for manufacturing to insure rugged, reliable emergency equipment.
- 3 Automatic activation is accomplished via a rolamite type inertia switch. This type of switch is not affected by electrostatics, magnetic disturbances or radio frequency emissions. The inertia switch is designed to activate when the unit senses longitudinal inertia forces as required in TSO - C91.

NOTE: When properly installed, parallel to the line of flight, POINTER PORTABLE will not activate due to turbulence, normal operations, or aerobatics.

- 4 POINTER PORTABLE ELT (see Figures 1 and 2) consists of:
  - A. A high impact, fire retardant, waterproof case with carrying handle.
  - B. A solid state transmitter operating at the assigned emergency frequencies of 121.5 MHz. and 243.0 MHz. Normal transmission is modulated by a distinctive downswep tone.
  - C. A battery pack consisting of four magnesium "D" cells and interconnecting cable and plug assembly. The battery pack is available from your local POINTER dealer or direct from the distributor.
  - D. An antenna connector outlet for fixed or telescopic antenna.
  - E. A remote "ON-AUTO-OFF" control jack.
  - F. A microphone jack.
  - G. A master "ON-OFF-AUTO" switch.
  - H. An inertia switch with finger tip reset button.
  - I. A storable telescopic antenna.
  - J. An external whip antenna with coax cable.
  - K. Remote cabin switch kit. (Optional)
  - L. A preformed anodized quick-detach mounting bracket.
  - M. An operation and installation manual.
  - N. A warranty registration card.

**SECTION 2**  
**PRE-INSTALLATION**

- 2-1 POINTER PORTABLE is designed to be installed in the aft section or cabin of the aircraft. Submission of FAA Field Approval Form 337 is required. The installation and testing should be made by qualified personnel. Appropriate weight and balance computations shall be completed and entered in the Aircraft Logbook for each installation.
- 2-2 a. Remove POINTER PORTABLE from carton and verify master switch is in the "OFF" position (See Figure 1).

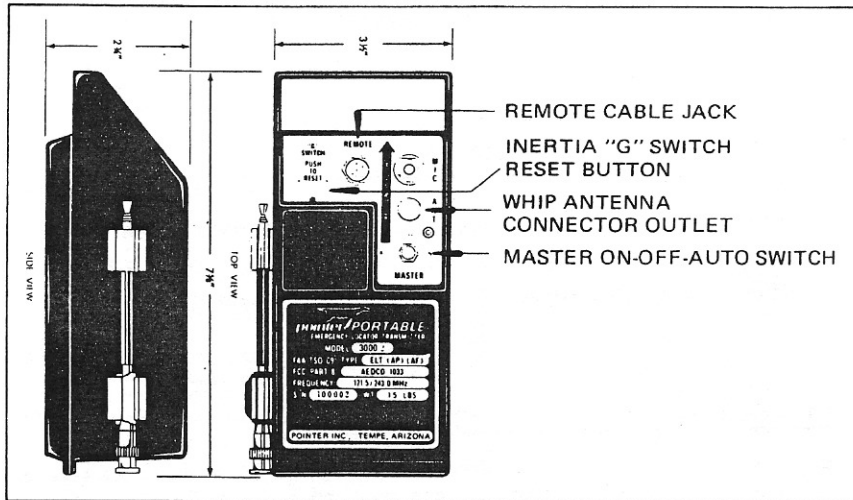

**FIGURE 1. POINTER PORTABLE OPERATING DETAILS**

- b. Press "G" switch reset button in firmly.
- c. Place master switch to "AUTO" position.
- d. Shake the unit firmly parallel to the "DIRECTION OF FLIGHT" arrow on the unit face. A tone will be heard on the monitoring radio at 121.5 MHz. During test a decreasing tone will be heard before the typical "WARBLING" tone begins. Reset "G" switch to turn unit off.
- e. Place the master switch in the "ON" position. Unit should again operate.
- f. Place master switch in the "OFF" position. POINTER PORTABLE IS NOW READY FOR INSTALLATION.

**NOTICE**

IF FOR ANY REASON POINTER PORTABLE DOES NOT TRANSMIT DURING ANY OF THE ABOVE TESTS, REPEAT THE PROCEDURES. IF UNIT STILL FAILS TO OPERATE, RE-PACKAGE THE ENTIRE UNIT AS SHIPPED, COMPLETE THE REGISTRATION CARD, PLACE A NOTE OF EXPLANATION AND THE REGISTRATION CARD INSIDE THE BOX AND RETURN UNIT TO DEALER OR DISTRIBUTOR FOR REPLACEMENT.

## SECTION 3

### INSTALLATION INSTRUCTIONS

#### 3.0 GENERAL

The following instructions are a general guide for the installation of the POINTER PORTABLE Aircraft Emergency Locator Transmitter. Installation shall be made in accordance with the requirements of FAA document AC 43-13-2, ACCEPTABLE METHODS, TECHNIQUES, & PRACTICES — AIRCRAFT ALTERATIONS. Each installation must satisfy airworthiness requirements pertinent to type.

#### **CAUTION!**

INSTALLATION IN THE PRESSURIZED AREA OF AN AIRCRAFT CONSTITUTES A MAJOR MODIFICATION. CONSULT LOCAL FAA REGIONAL ENGINEERING OFFICE BEFORE PROCEEDING.

#### 3.1 MOUNTING LOCATION — FIXED-WING AIRCRAFT

- a. The POINTER PORTABLE ELT should be mounted as far aft as possible. Location should be chosen to afford easy and repeated access to the ELT for testing, servicing, and manual activation/deactivation when the aircraft is on the ground.

#### **NOTE:**

Mounting location should afford easy removal of the ELT from the aircraft for detached operation.

- b. Select an area in the cabin such as between the seats in the luggage area, cabin floor, or any flat surface parallel to the longitudinal axis of the aircraft. Assure that the mounting area is solid.
- c. It is important that the unit be mounted PARALLEL TO or SLIGHTLY ABOVE the line of flight. The POINTER PORTABLE ELT must be solidly mounted. DO NOT install in an area subject to flexing or drumming vibrations. See Section 3.3 and 3.4 for installation details.

### 3.2 MOUNTING LOCATION — ROTARY-WING AIRCRAFT (HELICOPTER)

- a. The POINTER PORTABLE ELT must be located on or as close as possible to the primary structure supporting the rotor shaft and transmission. This location must be accessible for manual activation/deactivation, testing, and servicing when the helicopter is on the ground. See Section 3.4 for installation details.

**NOTE:**  
Mounting location should afford easy removal of the ELT from the helicopter for detached operation.

**FIGURE 2. POINTER PORTABLE ELT MAJOR SYSTEM COMPONENTS:**

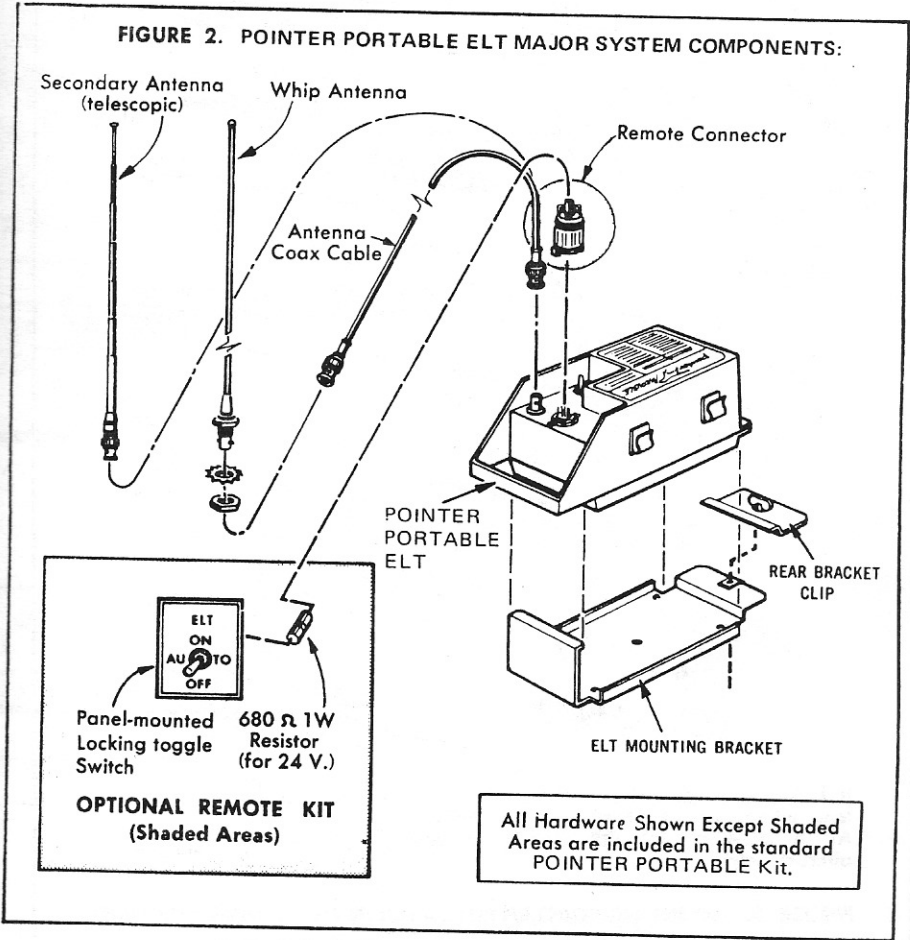

- NOTES: 1. Transmitter may be rotated Longitudinally to mount but must Face Forward as shown by the arrow.
2. Mounting surface must be flat and rigid over the entire area and of 2024.T3 AL ALY (or equivalent) material.

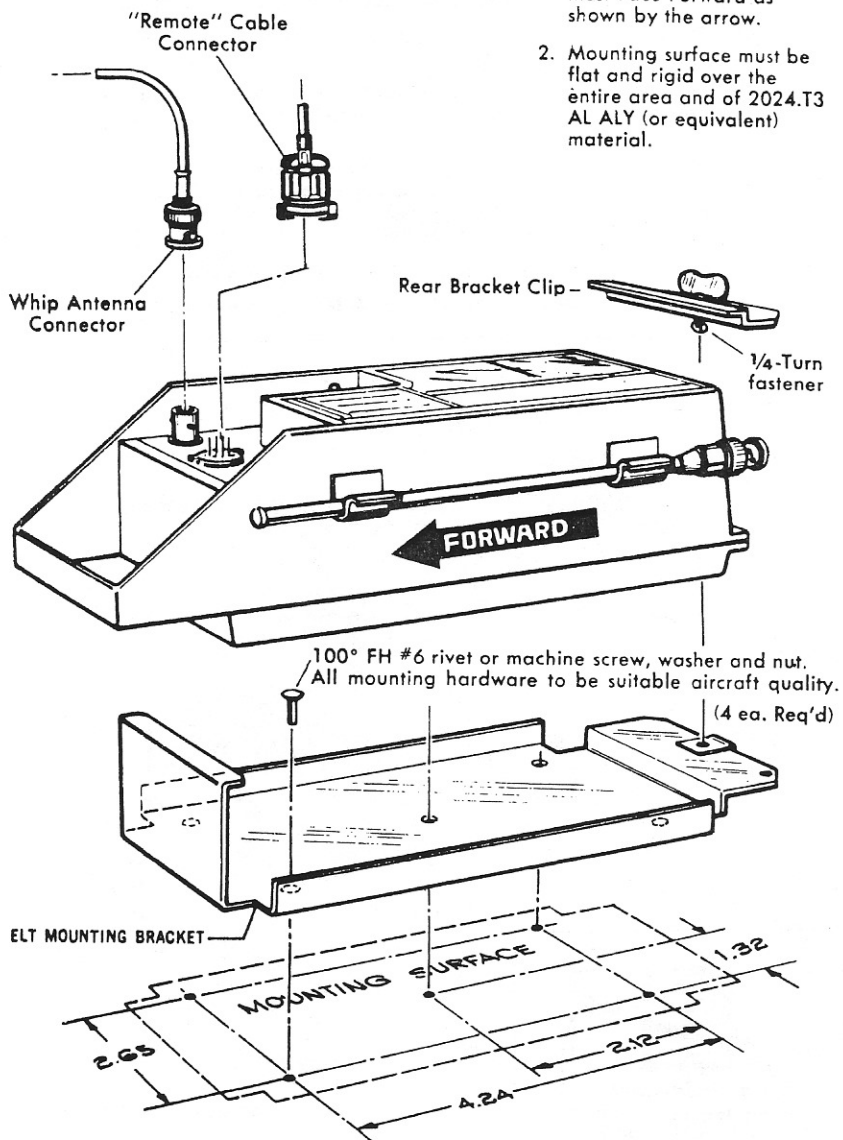

It is important that the unit be mounted PARALLEL TO the longitudinal axis of the aircraft. DO NOT MOUNT THE UNIT AT A DOWNWARD OR NEGATIVE ANGLE. (Fixed-wing aircraft only)

**FIGURE 3. MOUNTING POINTER PORTABLE IN FIXED-WING AIRCRAFT**

**NOTE:**

Prior to installing the ELT transmitter, check that battery replacement date is marked in the space on the label at the end of the unit.

- 3.3-1 Attach mounting bracket to the aircraft structure so that, when unit is installed, the "DIRECTION OF FLIGHT" arrow on the ELT control face points forward in the direction of flight. Drill four holes and attach the mounting bracket with 100° Flat head #6 rivets or screws. All attaching hardware must be of material and type suitable for Aircraft application. Heads must be flush with bracket surface.
- 3.3-2 Figure 3 shows a typical fixed-wing aircraft installation. Insert POINTER PORTABLE into the mounting bracket and position rear bracket clip over the end flange of the unit case. Turn the winged fastener a quarter turn to lock into place.
- 3.3-3 Reset the "G" Switch by pushing the protruding reset button on the ELT control face.
- 3.3-4 Place the Master Switch in the "Auto" position.
- 3.3-5 Record the installation in Aircraft Logbooks.
- 3.3-6 A remote whip antenna and coaxial cable are provided for external mounting. See Section 3.5 for antenna mounting details.
- 3.3-7 EXTERNAL MARKING. The external surface of the aircraft (or Helicopter) may be marked to indicate transmitter location.

**3.4 INSTALLATION DETAILS — ROTARY WING (HELICOPTER)**

- 3.4-1 All mounting instructions are identical to Fixed-Wing with the exception of the mounting angle as shown in Figure 4.

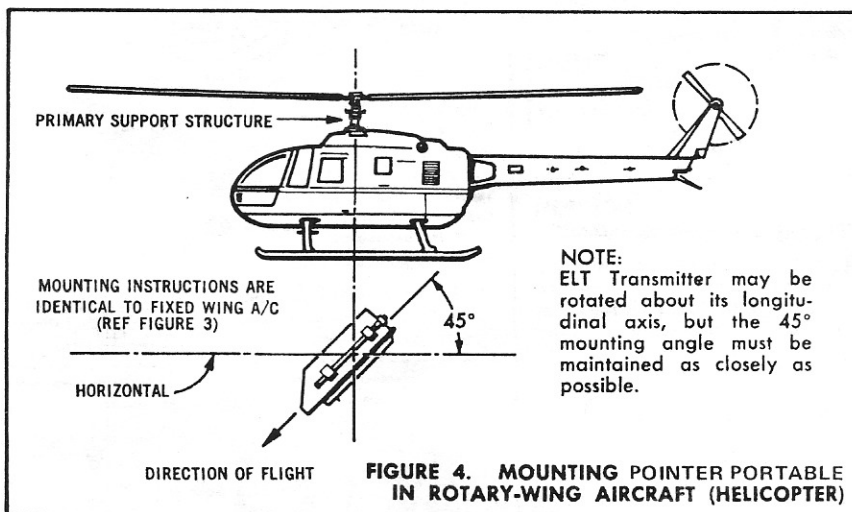

### 3.5 WHIP ANTENNA LOCATION AND MOUNTING

3.5-1 The POINTER PORTABLE Whip Antenna and coaxial cable are provided to permit external antenna radiation. Use ONLY the cable furnished with the unit.

Whip antenna should be mounted as far aft as possible on the surface of the aircraft (or helicopter) as this area is normally less susceptible to impact damage.

Pay particular attention to the following:

- (a) Mount Whip Vertically on the upper surface of aircraft (or helicopter).
- (b) Locate so as to minimize RF coupling from adjacent communications antennae. Maintain maximum practical distance from all other antennae.
- (c) Must not foul other antennae when whipped in flight.
- (d) Mount Whip antenna as close as possible to transmitter. Neatly coil and tie any excess in the 5 foot coax cable.

NOTE: COAXIAL CABLE MUST NOT BE CUT OR ALTERED.

### 3.5.2 WHIP ANTENNA INSTALLATION

Figures 5 and 6 illustrate details of Metal and Fabric-skin aircraft antenna installations.

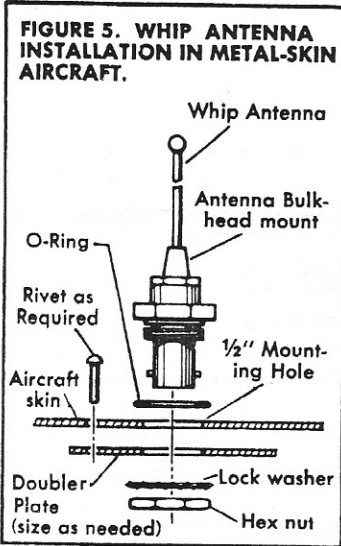

### 3.5.3 ANTENNA MODIFICATION

For high performance aircraft.

The POINTER PORTABLE Whip antenna may be modified to reduce wind-loading at higher speeds as shown below in Figure 7. (See Section 7 for max. speed.)

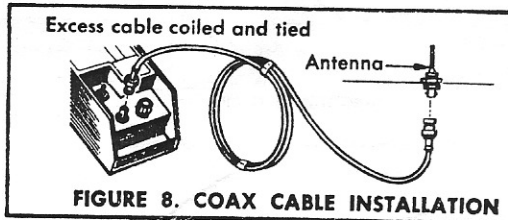
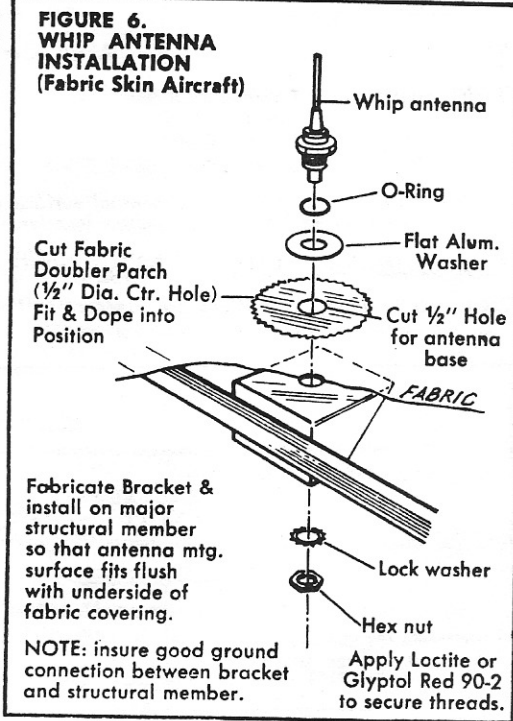
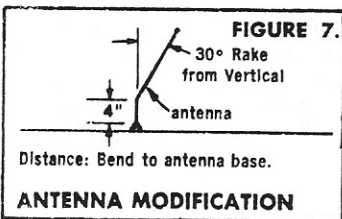



### 3.6 REMOTE SWITCH OPTION

The Optional Remote Switch feature is recommended for all installations where the transmitter is inaccessible to the pilot in flight. This option enables the pilot to remotely control the transmitter in flight. This is also useful for ground testing without gaining access to the transmitter.

3.6-1 Items included in the Remote Switch kit are listed below:

DESCRIPTION	QTY.
Toggle switch, Locking, DPDT	1
Connector (Locking)	1
Warning Label	1
Resistor (680 $\Omega$ , 1W) (24 V. USE ONLY)	1
Washer, Locking	1
Nut, Hex Head	1
Face Plate, ON/OFF/AUTO	1

3.6-2 The Remote Switch wiring diagram is shown in Figure 9.

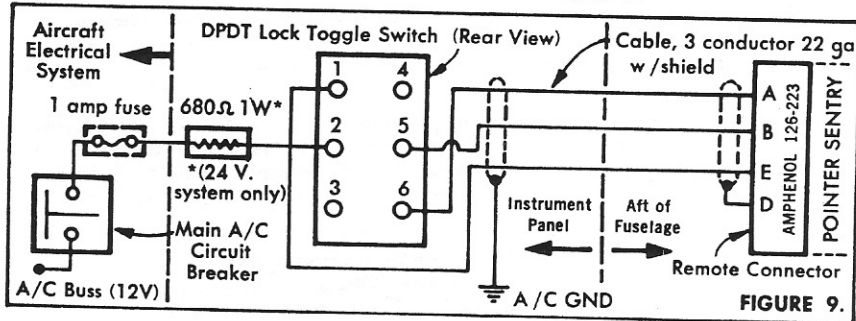

3.6-3 Select a location on the instrument panel for the Remote Switch / Face Plate assembly and the warning label. Drill a  $\frac{1}{4}$ " hole for switch installation.

3.6-4 Figure 10 shows wiring details for the connector and remote switch. Connect the wires as shown in Figure 9 using ONLY the connector and switch supplied in the kit.

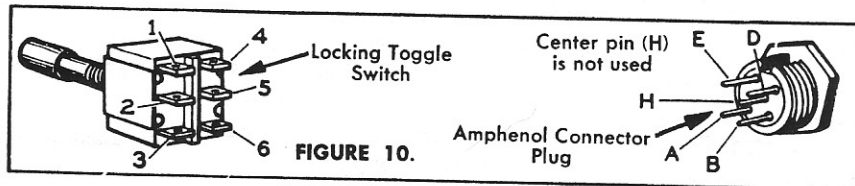

- 3.6-5 At pilot's end of cable, remove outer cable covering, form shielding into pigtail. Connect pigtail to aircraft ground.
- 3.6-6 At transmitter end of cable, remove cable covering and form shielding pigtail. Connect with pin D of the remote connector.
- 3.6-7 An in-line fuse or circuit breaker (1 amp max.) must be installed in the aircraft power circuit to the Remote Switch.
- 3.6-8 24V/28V aircraft. The 680 ohm, 1W resistor included in the remote switch kit must be wired in series with the 24V/28V Buss as shown in Figure 9. DO NOT USE resistor in 12V installations.
- 3.6-9 Mating the remote connector to the transmitter. Before mating the connector to the transmitter, apply sufficient silicone grease compound (DC-4) to mating surfaces that the surplus is forced out during connection for a moisture seal.
- 3.6-10 Install the locking toggle switch in the instrument panel with the face plate and secure with the locking washer and hex nut.
- 3.6-11 Affix the warning label to the instrument panel above, below, or adjacent to the Remote Switch/Face Plate to comply with FCC Requirements. This completes Remote Switch installation.

**SECTION 4**  
**FUNCTIONAL TESTING**

**4.0 GENERAL**

The POINTER PORTABLE ELT System must undergo a functional test for the following reasons:

- (a) After initial installation
- (b) After system maintenance, such as battery pack replacement
- (c) Thereafter at owners or operators discretion.

**4.1 TEST PREPARATION**

- 4.1-1 Visually inspect unit, connections and mounting bracket occasionally for cleanliness and secureness. Check fixed antenna mounting for tightness. Verify switch in "AUTO" position.
- 4.1-2 Test unit occasionally using procedure outlined in FAA advisory circular AC-20-81. **DON'T** overtest. If more than one cumulative hour of testing occurs before the replacement date of the battery pack, the pack should be replaced. **DO NOT USE THE VOICE FUNCTION DURING TEST PERIODS.**
- 4.1-3 The clarity of the voice modulation function will depend upon the microphone type used. Modulation level is intentionally low to prevent total carrier interruption during voice transmissions. Remember to conserve batteries, do not use voice function until you are positive search aircraft are in the area.

**NOTE:** Where aircraft comm. receiver is used:

- (a) Switch receiver ON
- (b) Tune to 121.5 MHz
- (c) Deactivate squelch
- (d) Turn up receiver volume until slight background noise is heard.

**4.2 POINTER PORTABLE FUNCTIONAL DETAILS**

- 4.2-1 **MANUAL MODE** (POINTER PORTABLE unit installed without the remote switch option)  
The unit Master Switch functions are as follows:

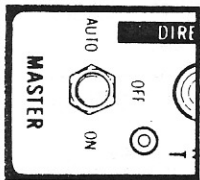

- AUTO:** Used to arm the POINTER PORTABLE for automatic activation by the "G" switch only.
- ON:** Used to activate the transmitter for test or emergency situations. The ON switch bypasses the Rolamite "G" switch.
- OFF:** Used to de-activate transmitter or to insure non-activation by handling.

- 4.2-2 **"G" Switch:** Used to activate the POINTER PORTABLE in emergency situation. The "G" switch can be operated by impact only. The "G" switch may be reset after intentional or emergency activation by depressing the small "Push to Reset" button on the unit face.

**4.2-3 REMOTE MODE (POINTER PORTABLE unit installed WITH the remote switch option)**  
 The Remote Switch functions are as follows:



- ON:** Used to remotely activate the transmitter for a test or emergency situation. An example of such an emergency situation would be a forced landing with an impact insufficient to activate the Rolamite "G" switch.
- AUTO:** Used to arm the POINTER PORTABLE for automatic activation by the "G" switch only.
- OFF:** Used to de-activate the transmitter after automatic activation by the Rolamite "G" switch.

**4.3 FUNCTIONAL TEST OF AIRCRAFT-MOUNTED POINTER PORTABLE**

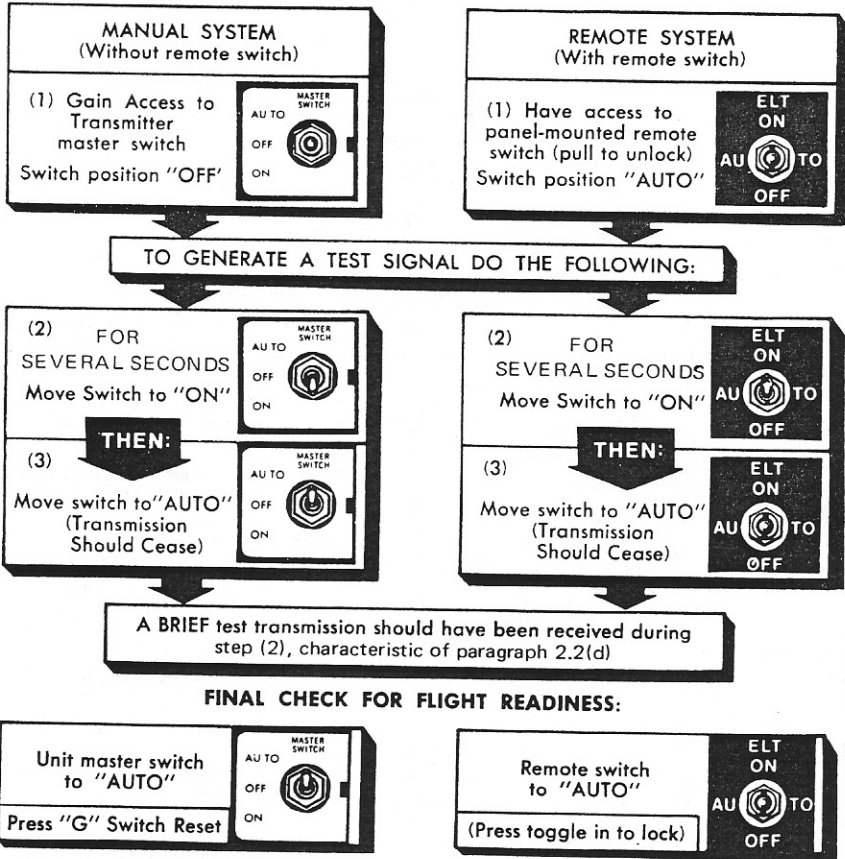

**4.4 MAINTENANCE**

4.4-1 If the unit fails to operate properly during the functional test, remove only the main unit and return to manufacturer for inspection and repair. REMEMBER to allow sufficient time for the unit to completely activate as described in PAR. 2-2(d).

**SECTION 5**  
**OPERATING INSTRUCTIONS**

5.0 GENERAL. Your POINTER PORTABLE ELT has been engineered to provide the most reliable operation possible. Every contingency has been considered in the design and construction of the PORTABLE system. The following section will acquaint you with the simple operational procedures of POINTER PORTABLE. It is recommended that you familiarize yourself thoroughly with these procedures and have them firmly in your mind to add to your flying confidence.

- 5.1 It is recommended that the following steps be taken to insure the best possible operation in an emergency:
- (a) Become thoroughly familiar with the POINTER PORTABLE instructions
  - (b) Keep them on hand in the aircraft at all times
  - (c) Have the necessary tools (e.g. screw driver or Dzus fastener driver) to insure speedy access to the transmitter in an emergency
  - (d) Visually inspect the unit at regular intervals for cleanliness and secureness. Check Whip antenna mounting and cable connections for tightness.

5.1-1 OPERATING POINTER PORTABLE IN THE "FIXED" MODE (IN AIRCRAFT)  
The following table gives the switch positions and functions for various situations:

MANUAL SYSTEM (Pointer Portable System Without Remote Switch)			REMOTE SYSTEM (Pointer Portable System With Remote Switch)		
MODE	Master Switch on unit	FUNCTION	Master Switch on unit	Remote Switch on panel	FUNCTION
AUTO	"AUTO" (Normal Flight Setting)	Portable automatically activated if "G" switch senses level of $5 \pm 2/0g$ and duration of $11 \pm 5/0$ Milliseconds.	"AUTO" (Normal Flight Setting)	"AUTO" (Normal Flight Setting)	Portable automatically activated if "G" switch senses level of $5 \pm 2/0g$ and duration of $11 \pm 5/0$ Milliseconds.
MANUAL	"ON"	Overrides "G" switch, and turns PORTABLE on so it can be tested for proper operation on the ground OR: (ONLY IF TRANSMITTER IS ACCESSIBLE WHILE AIRBORNE) Airborne testing . . . or, If emergency situation is imminent and pilot wishes to activate PORTABLE prior to emergency.	"AUTO"	"ON"	Overrides "G" switch and turns PORTABLE on so it can be tested for proper operation on the ground or while airborne. OR: If emergency situation is imminent and pilot wishes to activate PORTABLE prior to emergency.
OFF	"OFF"	Turns POINTER PORTABLE off in preparation for removal from aircraft or to discontinue signal after rescue.  <div style="border: 1px solid black; padding: 2px; width: fit-content; margin: 10px auto;">NOTE:</div> If inadvertent activation occurs in system without the remote switch, the aircraft must be landed at earliest opportunity and the "G" switch reset. OR, if the transmitter is accessible in the air, the "G" switch must be reset immediately.	"AUTO"	"OFF"	Turns Pointer Portable off if inadvertent activation of the "G" switch should occur during flight. The unit will not transmit as long as the remote function senses voltage at the main aircraft buss. Loss of voltage at the main buss by turning off aircraft master switch or crash landing will allow Pointer Portable to transmit even if the remote switch remains in the "off" position. NOTE: In case of inadvertent activation, after landing and engine shutdown place aircraft master switch back to "on" position to prohibit unauthorized distress transmission until "G" switch on Pointer Portable has been manually reset.

5.1-2 After a forced landing, if aircraft receiver is operable, listen on 121.5 MHz for POINTER PORTABLE transmissions. Ensure that Whip antenna is clear of obstructions.

5.1-3 The range of POINTER PORTABLE varies according to weather and topography. In general, the swept tone signal can be heard up to 100 miles, depending on search aircraft altitude, topography and aircraft attitude. Stay close to the downed aircraft to permit easier spotting by airborne searchers.

## 5.2 OPERATING POINTER PORTABLE IN THE PORTABLE MODE

5.2-1 After forced landing or aircraft accident it may be desirable to use POINTER PORTABLE in the portable mode. Various reasons may necessitate this, such as:

- (a) Broken or disabled whip antenna
- (b) Severed whip antenna cable
- (c) Danger of fire or explosion in aircraft
- (d) Temperature extremes in aircraft
- (e) Poor transmitting location

### 5.2-2 REMOVAL OF TRANSMITTER FROM AIRCRAFT

NOTE: ACCOMPLISH AS QUICKLY AS POSSIBLE TO RESUME OR START EMERGENCY SIGNAL

- (a) turn the unit master switch to "OFF" position
- (b) disconnect whip antenna cable
- (c) disconnect Remote switch cable (if applicable)
- (d) turn winged nut on rear bracket clip to release transmitter (Remove)
- (e) Remove the telescopic antenna from the stowage clips and insert into the ANT receptacle. Extend antenna fully.
- (f) Turn Unit master switch to "ON" position. DO NOT USE "AUTO" POSITION!

5.2-3 Consider such factors as Terrain, Temperature and Precipitation when choosing a location for the transmitter to radiate from.

BEST TRANSMISSION MAY BE OBTAINED BY:

- (a) Keeping antenna vertical
- (b) Standing transmitter upright on a metallic surface, such as an aircraft wing or stabilizer.
- (c) If terrain prohibits good transmission (such as a deep valley or canyon) place the transmitter on high ground or hold in hand on high place.



IN FREEZING WEATHER  
PLACE TRANSMITTER  
INSIDE JACKET TO  
KEEP BATTERY  
WARM.

FIG. 11

### 5.3 BATTERY LIFE VS. TEMPERATURE

5.3-1 Temperature extremes and precipitation. Cold has a direct effect on battery life. Figure 12 illustrates the relationship.

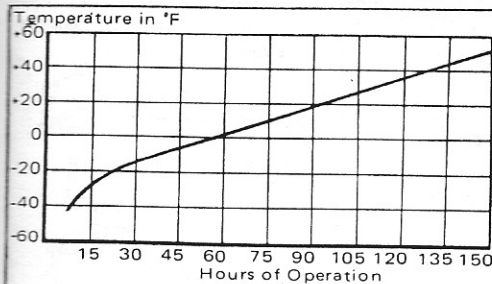

FIGURE 12.  
POINTER PORTABLE BATTERY LIFE  
VS. TEMPERATURE GRAPH

YOUR POINTER PORTABLE ELT is supplied with batteries (magnesium) to withstand the environmental extremes. However, even the life of magnesium batteries can be extended by the following steps:

- (a) In freezing weather, place transmitter inside jacket or coat to keep the battery warm. Let antenna extend outside jacket.
- (b) Keep all moisture and ice away from the antenna connection and the remote connector pins.

CAUTION: DO NOT TURN POINTER PORTABLE OFF — EVEN AT NIGHT as search aircraft may be enroute around the clock. Even when you have been sighted or think you have, the spotting aircraft may not be able to relay an accurate or timely "fix" on your position without a continued signal.

5.3-2 ONLY WHEN THE RESCUE TEAM APPEARS discontinue signaling by using the "OFF" position.

**SECTION 6**  
**BATTERY INFORMATION AND REPLACEMENT**

**6.0 GENERAL**

- 6.1 Power is derived from a single battery pack consisting of 4 - 1.8 V Magnesium "D" size batteries in series. This assembly has been moisture-sealed and fitted with a battery lead connector.
- 6.2 WHEN TO REPLACE BATTERY PACK:
- 6.2-1 In accordance with FAA regulations, batteries must be replaced after 3 years shelf or service life or for any of the following reasons:
- (a) After the transmitter has been used in an emergency situation (including any inadvertent activation of unknown duration).
  - (b) After the transmitter has been operated for more than one cumulative hour (e.g. time accumulated in several tests and an inadvertent activation of known duration).
  - (c) On or before battery replacement date.  
(Battery replacement date is marked on the label at end of transmitter.)

Check with your local dealer or write the distributor  
for replacement battery packs.

**WARNING: DO NOT ATTEMPT TO RECHARGE BATTERY PACK!**

**6.3 REMOVING THE TRANSMITTER (See Figure 13)**

- 6.3-1 Transmitter must be removed from aircraft for battery replacement by the following steps:
- (a) Place the Master Switch in the "OFF" position.
  - (b) Disconnect the antenna cable, and, where applicable, the remote connector.
  - (c) Grasping the transmitter firmly, turn winged nut on the rear bracket clip and remove transmitter from mounting bracket.

**6.4 REMOVE BATTERY PACK AS FOLLOWS:**

- (a) Remove 6 screws from base plate.  
(Retain Neoprene washers)
- (b) Remove base plate (save gasket), and disconnect the battery/transmitter connectors.
- (c) Remove and replace battery pack, reversing the above procedure.

**WARNING: ENSURE THAT BATTERY PACK IS NOT SUBJECT TO SHORT CIRCUIT, FIRE, OR HIGH TEMPERATURES.**

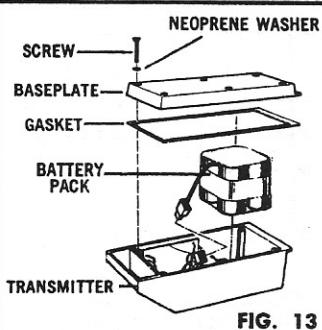

**FIG. 13**

- 6.5 Apply new battery replacement date label, supplied with replacement pack, on transmitter end prior to re-installing transmitter in aircraft, test in accordance with Section 4.3 - Functional testing, Page 11.
- 6.6 Re-installing transmitter in aircraft, test in accordance with Section 4.3 - Functional testing, Page 11.

MODEL TYPE	OPERATING LIFE		SHOCK	VIBRATION
	Low-Temp Requirements: -65°C soak; 30 min. Operate -20°C for 48 hrs. Meet specifications at end of test.	Hi-Temp Requirements: +71°C soak; 30 min. Operate +55°C for 2 hrs. and meet specifications.		
AP/AF (FIXED EXTERNAL ANTENNA)	<b>Test Results:</b> Modulation: Range - 1560 Hz - 770 Hz Rate - 2.4 Hz Transmitter: Frequency - 121.503778 MHz Duty Cycle - 38.5% MOD. Factor - 100% PERP - 121.5 MHz; 142 MW 243.0 MHz; 89 MW	<b>Test Results:</b> Modulation: Range - 1430 Hz - 525 Hz Rate - 2.7 Hz Transmitter: Frequency - 121.499253 MHz Duty Cycle - 37.2% MOD. Factor - 100% PERP - 121.5 MHz; 360 MW 243.0 MHz; 230 MW	<b>Requirement:</b> 50 g impact, 1 msec pulse, 6 axis. Operate after each drop and meet specifications.	<b>Test Results:</b> Modulation: Range - 1450 Hz - 705 Hz Rate - 2.3 Hz Transmitter: Frequency - 121.501308 MHz Duty Cycle - 39.2% MOD. Factor - 100% PERP - 121.5 MHz; 200 MW 243.0 MHz; 191 MW
AP/P (PORTABLE TELESCOPIC ANTENNA)	Modulation and sweep measurements same as above except: PERP - 121.5 MHz; 89 MW 243.0 MHz; 80 MW	Modulation and sweep measurements same as above except: PERP - 121.5 MHz; 230 MW 243.0 MHz; 200 MW	Modulation and sweep measurements same as above except: PERP - 121.5 MHz; 208 MW 243.0 MHz; 166 MW	Modulation and sweep measurements same as above except: PERP - 121.5 MHz; 208 MW 243.0 MHz; 166 MW

**MINIMUM ELECTRICAL REQUIREMENTS**
**MODULATION CHARACTERISTICS:**

Range - 1800 Hz - 300 Hz  
 Excursion - 700 Hz minimum  
 Rate - 2 Hz - 4 Hz  
 Bandwidth - 25 KHz max.

Duty Cycle - 33% minimum  
 Modulation Factor - 85% minimum  
 Peak Effective Radiated Power (PERP) - 75 MW, minimum  
 (121.5 MHz and 243.0 MHz after 48 hours at -20°C (-4°F)).

**TRANSMITTER:**

Frequency 121.493925 MHz - 121.506075 MHz  
 (Single frequency shown for clarity as second frequency (243.0 MHz is harmonically related to fundamental).)

**ENVIRONMENTAL TESTS**
**TEST RESULTS**

1. **Altitude Test.** Requirements: Non-operating, S/L to 50,000 ft. and hold for 15 min. Reduce altitude at 10,000 ft/min to S/L. Operate and meet specifications.

2. **Decompression Test.** Requirements: Non-operating, 40,000 ft. (decompression) and hold for 10 min. Reduce altitude at 10,000 ft/min to S/L. Operate and meet specifications.

3. **Overpressure Test.** Requirements: Non-operating, S/L to -15,000 ft. (50 in/Hg) and hold for 3 min. Reduce pressure to S/L. Operate and meet specifications.

**MOISTURE TESTS**

- Humidity Test.** Requirements: Non-operating; soak at 85% to 95% relative humidity - temp. varying between 30 to 50°C in cycles for 48 hrs. Operate and meet specifications within 4 hrs. following test.
- Immersion Test.** Requirements: Non-operating; immerse unit in salt water for 15 hrs. Remove, operate and meet specifications.
- Waterproofness Test.** Requirements: Operating; unit subjected to simulated rain for 15 min. Meet specifications during test.

**TEST RESULTS**

**POINTER PORTABLE** water proofness was demonstrated by immersing the unit in salt water. The telescopic antenna extending above the unit and operating for 24 hrs. Electrical characteristics measured at the end of test were:  
 Modulation: Range - 1450 Hz-705 Hz  
 Rate - 2.3 Hz  
 Transmitter:  
 Frequency - 121.501917 MHz  
 Duty Cycle - 39.2%  
 MOD. Factor - 100%  
 PERP - 121.5 MHz; 208 MW  
 243.0 MHz; 166 MW

**System Weights:**

**TRANSMITTER** (including primary battery, telescopic antenna & mtg. brackets) 1.9 lb. (.86 Kg)  
**WHIP ANTENNA** (including coaxial cable and connector) 0.25 lb. (.11 Kg)

7 3/4" x 3 1/2" x 2 3/4" (19.4 Cm x 9 Cm x 7 Cm)

Dimensions (Transmitter)

### WARRANTY

*POINTER, INC.* warrants each new Pointer Portable Model 3000 Emergency Locator Transmitter to be free of defects in material and workmanship, (excluding battery pack) for lifetime to the original purchaser. The Company will repair or replace for the original purchaser, free of charge, at its factory, any part or parts found to be defective under normal use and service — *PROVIDED* that the enclosed warranty card is properly completed and mailed within 15 days after installation and is on file with *POINTER*. This warranty does not cover cost of removal or reinstallation of unit in the aircraft.

This warranty does not cover defects resulting from alterations, improper use, or installation, tampering or failure of the purchaser to follow normal operating procedures outlined in the user's instructions, nor, for example, does it cover damage resulting from acts of God, such as floods, tornadoes, or lightning.

This warranty is made only to original purchasers in the United States and does not cover the responsibility for the shipping expenses in returning the transmitter sold or any part thereof to *POINTER* or returning the transmitter or part to the purchaser.

THE WARRANTY PROVISIONS SET FORTH ABOVE ARE IN LIEU OF ANY AND ALL OTHER WARRANTIES, WHETHER EXPRESSED OR IMPLIED, INCLUDING THE WARRANTIES OF MERCHANTABILITY OR FITNESS FOR A PARTICULAR PURPOSE, AND ANY OTHER OBLIGATIONS OR LIABILITY WHATSOEVER ON THE PART OF *POINTER* OR ANY OF ITS FRANCHISED DEALERS.

### NOTICE

THE FOLLOWING INSTRUCTIONS ARE A GENERAL GUIDE FOR THE INSTALLATION OF *POINTER PORTABLE AUTOMATIC EMERGENCY LOCATOR TRANSMITTERS*. INSTALLATION SHOULD BE MADE IN ACCORDANCE WITH FAA PART 43 AND BY AN APPROVED INSTALLATION FACILITY.



MFG BY POINTER, INC. Freeway Commerce Center  
1453 W. Alameda Dr. / Tempe, Arizona 85282 U.S.A.